

Insulated Unit Type

Features

- For temperatures exceeding 430°F (221°C) to 700°F (371°C)
- Furnished as an attached unit. Disk's nameplate rating must be established at the cold face temperature of the insulation
- NOT available for Two-Way disks or disks with ring or plate vacuum supports
- Insulated Units are supplied armored with required insulation and gaskets for service above 430°F (221°C) to 700°F (371°C). Standard armor is carbon steel, gaskets are compressed fiber, and insulation is spun alumina/silica. This insulation prohibits use with liquids and some corrosives
- For temperatures exceeding 700°F (371°C) contact ZOOK
- Contact ZOOK for flow reduction factor when using Insulated Unit

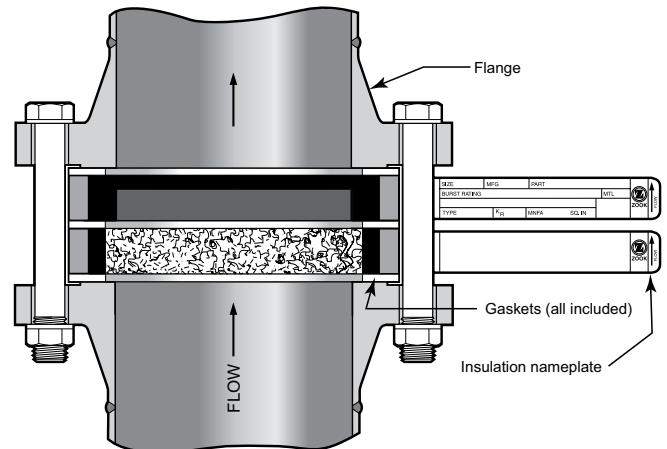
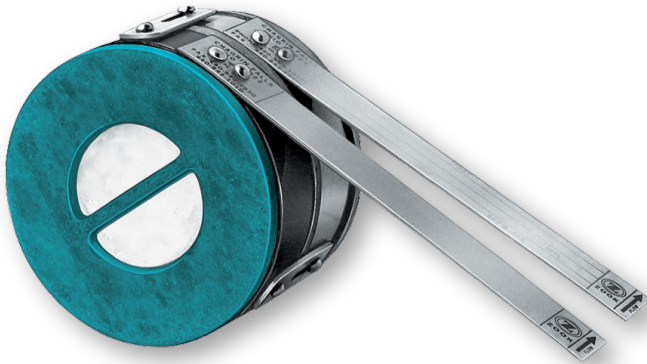

Note:
Insulated Disks cannot be used with liquids, hydrofluoric and phosphoric acids or concentrated alkalis