



# INSTALLATION INSTRUCTIONS

## Model ZAM Plus Rupture Disk Monitor

### GENERAL INFORMATION

The ZOOK Model ZAM Plus rupture disk monitor, when used in conjunction with ZOOK Rupture Disk(s) with "Zensor" or similar devices is designed to signal the operator in the event of a disk rupture condition.

The unit is designed to continuously monitor 2, 4, 6, or 8 field contacts (Intrinsically Safe (I.S.) Devices) depending which unit you have purchased. Housed in a NEMA 12 rated enclosure, the monitor contains an integral AC/DC power supply, 2 or more single channel, galvanically isolated intrinsic safety (I. S.) barrier module with a built-in amplifier that transfers discrete signals (NAMUR sensors/mechanical contacts) from a hazardous area to a safe area. Each barrier has a Normally Open (NO) and a Normally Closed (NC) pair of contacts rated at 126.5 VAC @ 4 Amps (see Specifications for additional ratings). These contacts can be used for controlling relays, contactors, remote warning lights and etc.

The front panel has a window that allows the control operator to monitor the status of the internal Power Supply and I. S. Barriers, contains push buttons to test each channel individually and a push button (latch/unlatch) to reset/silent the Audible Alarm. Visible indicators are provided to indicate an alarm condition for each channel.

**The ZOOK model ZAM plus rupture disk monitor has intrinsically safe outputs for class I, II and III Division 1, Groups A, B, C, D, E, F, and G hazardous locations when installed per Figure #1 (DWG NO. ZQ 4127).**  
**NOTE: For applications involving highly electrically conductive fluids (less than 4kΩ total resistance) consult factory.**

**WARNING: To prevent the possibility of electrical shock and/or improper operation, installation should be performed only by qualified electricians and/or instrumentation personnel.**

### 1) MOUNTING

Installation and wiring of this unit should be done in accordance with the latest edition of the National Electrical Code and any local codes. The monitor must be mounted in upright position only and in a dry non-hazardous area where the operating temperature limits (-15°F to +140°F) will not be exceeded. Attach the unit to a wall or cabinet support brackets using appropriate hardware (Refer to Figure 2 for 'mounting-hole pattern').

### 2) POWER WIRING

**NOTE:** Refer to Figure 3 at the back of this Instruction Manual for the typical location of the components described in this Manual.

The monitor incorporates a small fused disconnect as part of the AC input power (L1) terminal block on terminal strip TS 3 - see Photo 1. This disconnect can be used to disconnect the internal AC voltage to the Power Supply and I.S. Barriers should they need to be replaced.

**NOTE:** This small disconnect DOES NOT shut off the AC power into the box. A separate circuit breaker or disconnect should be installed in the power line per local electrical codes to act as a power switch should the monitor package need to be serviced.

To operate the fused disconnect, simply pull back the lever on the left side of the disconnect. Inside the disconnect is a small 2A, 250V, glass, 5x20, slow time delay fuse (RadioShack, Catalog #: 270-1064). To access this fuse simply swing down the right side of the disconnect utilizing the tab shown in Photo 1. Photo 2 shows the fuse as positioned in the disconnect.

Remember to practice your "Lock-Out" procedures.

[www.zookdisk.com](http://www.zookdisk.com)

**Serving America, Central & South America**  
16809 Park Circle Drive, Chagrin Falls,  
Ohio 44022 USA  
Toll Free: +1 800 543 1043  
Phone: +1 440 543 1010  
E-mail: [sales@zookdisk.com](mailto:sales@zookdisk.com)

**Serving Europe, Middle East & Africa**  
Navigation House, Bridge Street  
Killamarsh, Sheffield,  
S21 1AL UK  
Phone: +44 (0) 1909 560999  
E-mail: [sales.europe@zookdisk.com](mailto:sales.europe@zookdisk.com)

**Serving Canada**  
4400 South Service Rd,  
Burlington, Ontario L7L 5R8 CA  
Toll Free: +1 800 370 6057  
Phone: +1 905 681 2885  
E-mail: [sales.canada@zookdisk.com](mailto:sales.canada@zookdisk.com)

**Serving Asia Pacific**  
Unit No.23A-05, Menara Landmark, No.12,  
Jalan Ngee Heng  
80000 Johor Bahru, Johor, Malaysia  
Phone: +60 (7) 2910099  
E-mail: [sales.asia@zookdisk.com](mailto:sales.asia@zookdisk.com)

**NOTE:** There should be NO AC power wiring above the blue INTRINSICALLY SAFE WIRING label on the sub-panel.

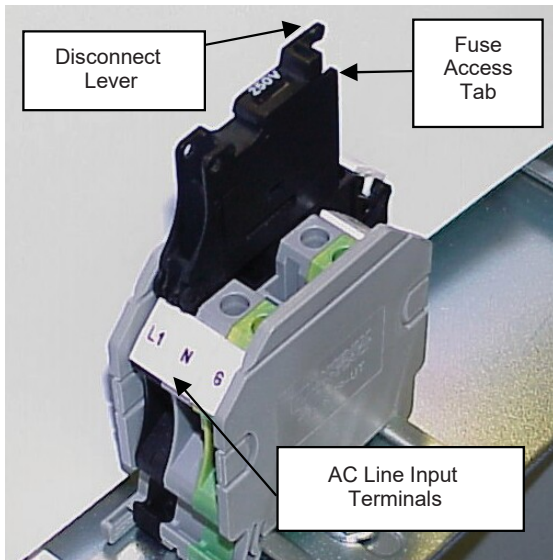

Photo 1

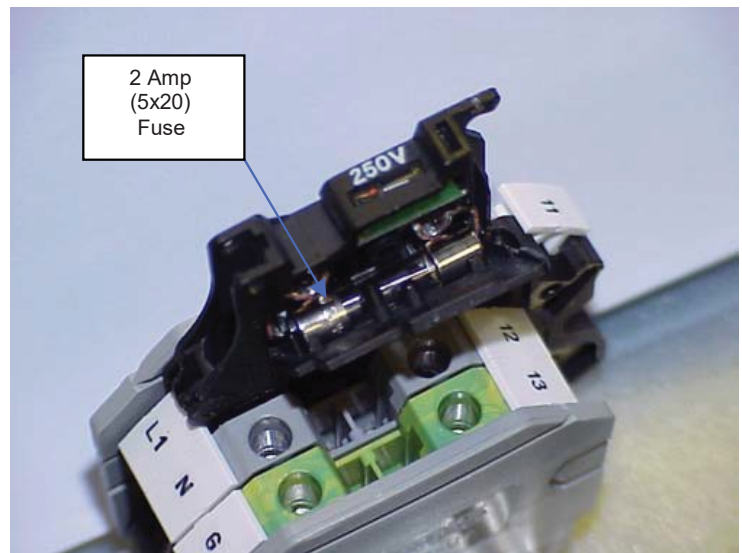

Photo 2

### 3) INPUT POWER (TERMINAL STRIP – TS 3)

#### a) Wire Preparation

To prepare the wire for insertion into a terminal block remove approximately 5/16" of the wire insulation. When using stranded wire be sure to twist all the strands together before trying to insert the wire into the terminal block. Bending the end of the wire will help to insert it into the terminal block.

To further assist you in the wire insertion operation turn the terminal screw (counter clockwise) to fully open the terminal port. Then insert the wire and tighten the terminal screw.

#### b) AC Power Connection

The AC to DC power supply in the ZAM Plus is design for a nominal input range of 100 VAC to 240 VAC. AC power input connections are connected to the terminal blocks adjacent to the Power Supply on terminal strip TS3.

**Connect the incoming power wiring as follows (See Photo 1 above):**

Black Lead (Hot) to L1

White Lead (Neutral) to N

Safety Ground (Green) to G

[www.zookdisk.com](http://www.zookdisk.com)

**Serving America, Central & South America**  
16809 Park Circle Drive, Chagrin Falls,  
Ohio 44022 USA  
Toll Free: +1 800 543 1043  
Phone: +1 440 543 1010  
E-mail: [sales@zookdisk.com](mailto:sales@zookdisk.com)

**Serving Europe, Middle East & Africa**  
Navigation House, Bridge Street  
Killamarsh, Sheffield,  
S21 1AL UK  
Phone: +44 (0) 1909 560999  
E-mail: [sales.europe@zookdisk.com](mailto:sales.europe@zookdisk.com)

**Serving Canada**  
4400 South Service Rd,  
Burlington, Ontario L7L 5R8 CA  
Toll Free: +1 800 370 6057  
Phone: +1 905 681 2885  
E-mail: [sales.canada@zookdisk.com](mailto:sales.canada@zookdisk.com)

**Serving Asia Pacific**  
Unit No.23A-05, Menara Landmark, No.12,  
Jalan Ngee Heng  
80000 Johor Bahru, Johor, Malaysia  
Phone: +60 (7) 2910099  
E-mail: [sales.asia@zookdisk.com](mailto:sales.asia@zookdisk.com)

### 4) INTRINSICALLY SAFE DEVICE WIRING (Terminal Strip – TS 1)

#### WARNING:

- a) All intrinsically safe (I.S.) wiring should be physically separated from non-intrinsically safe wiring by means of independent raceways, trays, or conduit.
- b) The I.S. wiring must enter/exits via the two (2) 'knock-outs' located on the top of the enclosure near terminal strip TS1.
- c) Intrinsically safe field wiring must fall within the following limits:

	Shunt Capacitance	Series inductance
Group A & B	less than 2.4 uF	less than 210 mH
Group C, E, & F	less than 16.8 uF	less than 840 mH
Group D & G	less than 75.0 uF	less than 1000 mH

All field I.S. wiring for the Zensor Disk(s) and/or similar devices should be done with good quality shielded instrumentation cable. The monitor end of the field wiring should be prepared as stated above in 3) a.

**Connect the field wiring as shown in Photo 3 below:**

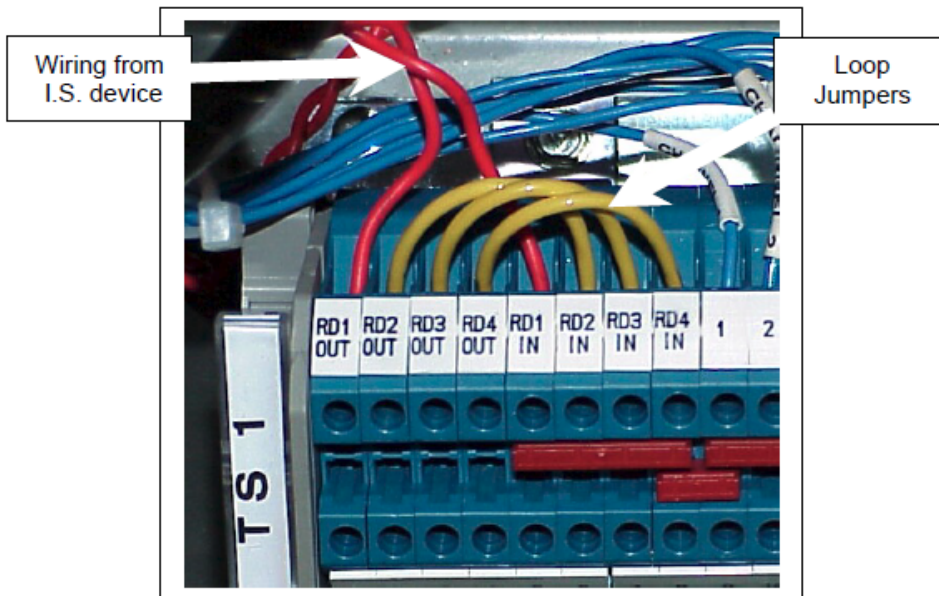

**PHOTO 3 – I.S. Devices should be connected in numerical order. Typical I.S. Input wiring for all ZAM Plus Monitors – 4 Channel shown.**

For Channel 1 signal: RD1 OUT  
RD1 IN  
For Channel 2 signal: RD2 OUT  
RD2 IN  
For Channel 3 signal: RD3 OUT  
RD3 IN

This configuration is typical for all ZAM Plus monitors. If ANY channel is unused, its' inputs should be jumpered together as illustrated (see Photo 3) by the short-loop jumpers to prevent false alarm conditions. Unit is factory supplied with jumpers on all channels.

### 5) I.S. BARRIER MODULE OUTPUTS

Each I.S. barrier module has a pair of relay outputs configured as follows:

- 1 Common - Terminal 7
- 1 Normally Open (NO) contact – Terminal 8
- 1 Normally Closed (NC) contact – Terminal 9

These outputs may be used to activate remote alarms and/or control valves, contactors or relays. When power is applied to the monitor the relay outputs do not change.

**NOTE: Relay contacts (NO – NC) change state only when the I.S. device OPENS (disk ruptures). The barrier sense the open I.S. circuit, energizes its' relay and changes contact state.**

Barrier Module output field wiring should be prepared as stated above in 3a).

Connect the output wiring field as shown in Photo 4 below:

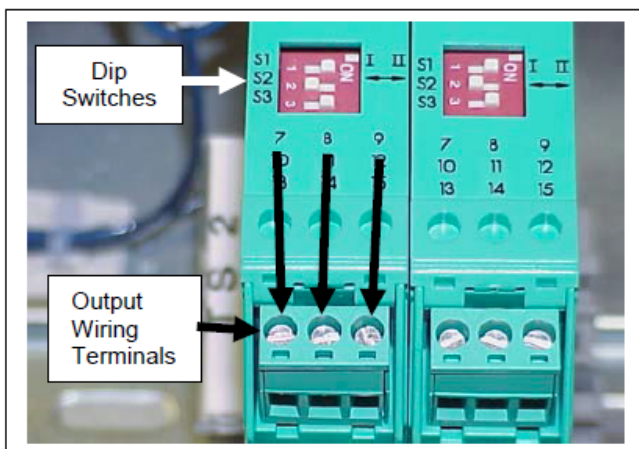

PHOTO 4

**NOTE: DO NOT change the position of any of the Dip Switches shown in Photo 4 above – doing so will alter the performance of the monitor.**

### 6) APPLY POWER-START-UP

Check all wiring to make sure there are no shorts, opens or misconnections. Apply power to the unit. The monitor should power up in the non-alarm condition – no lights lit on the door. The I.S. Barrier Module 'PWD' LEDs and Power Supply 'DC OK' LED should be lit. Press the Channel #1 'TEST' push button and verify the audible alarm sounds (Alarm Reset pushbutton must be unlatched), the Alarm Reset light, Channel #1 light and I.S. Barrier Module 'OUT' should be lit. If the Alarm Reset pushbutton is latched (button recessed) the Alarm Reset light will light but there will be NO audible alarm sound. This feature allows the operator to silence the audio while investigating and/or correcting the alarm event. Once the event has been resolved remember to unlatch the Alarm Reset pushbutton. Repeat the above test for all channels.

[www.zookdisk.com](http://www.zookdisk.com)

**Serving America, Central & South America**  
16809 Park Circle Drive, Chagrin Falls,  
Ohio 44022 USA  
Toll Free: +1 800 543 1043  
Phone: +1 440 543 1010  
E-mail: [sales@zookdisk.com](mailto:sales@zookdisk.com)

**Serving Europe, Middle East & Africa**  
Navigation House, Bridge Street  
Killamarsh, Sheffield,  
S21 1AL UK  
Phone: +44 (0) 1909 560999  
E-mail: [sales.europe@zookdisk.com](mailto:sales.europe@zookdisk.com)

**Serving Canada**  
4400 South Service Rd,  
Burlington, Ontario L7L 5R8 CA  
Toll Free: +1 800 370 6057  
Phone: +1 905 681 2885  
E-mail: [sales.canada@zookdisk.com](mailto:sales.canada@zookdisk.com)

**Serving Asia Pacific**  
Unit No.23A-05, Menara Landmark, No.12,  
Jalan Ngee Heng  
80000 Johor Bahru, Johor, Malaysia  
Phone: +60 (7) 2910099  
E-mail: [sales.asia@zookdisk.com](mailto:sales.asia@zookdisk.com)