

WARNINGS

Read the complete instructions before attempting to install the rupture disk and holder assembly.

- a) It is the user's responsibility for the design of adequate venting and installation of adequate vent piping or directional flow after rupture occurs with the rupture disk as intended. When size is specified, ZOOK assumes that adequate provisions have been made by the purchaser and/or user for proper venting of a system to relieve the specific pressure. Locate the rupture disk where people or property will not be exposed to the system discharge in the event of rupture. Vent toxic or flammable fumes to a safe location to prevent personnel injury or property damage.
- b) It is the user's responsibility to specify the burst pressure rating at the coincident temperature at which the rupture disk is to be used. A rupture disk is a temperature sensitive device. The burst pressure of the rupture disk is directly affected by its exposure to the coincident temperature. Failure to utilize a rupture disk at the specified coincident temperature could cause premature failure or over-pressurization of the system.
- c) Particles may discharge when the rupture disk ruptures. These particles may be part of the rupture disk itself, or other environmental matter in the system. It is the user's responsibility to ensure that particles are directed to a safe area to prevent personnel injury or property damage.
- d) Rupture disk service life is affected by corrosion, fatigue and physical damage. These conditions may de-rate the rupture disk to a lower pressure. The user should be prepared to handle a premature failure of the rupture disk. The media or other environmental conditions should not allow for any build-up or solidification of media on the rupture disk. This may increase the burst rating of the rupture disk.
- e) The customer and/or its installer shall be responsible for the proper installation of rupture disk device into a system.
- f) Customer and/or its installers shall be responsible for improper installation and physical damage resulting there from, including, but not limited to, damage resulting from leakage, improper torqueing, and/or failure to follow installation instructions.
- g) Extraneous stresses from vent line, supports surrounding structure, and subsequent structural changes must not be allowed to cause excessive and/or unequal forces on the disk.
- h) Vent piping must be adequately supported to withstand forces generated during blow-down conditions
- i) ZOOK standard Terms and Conditions of Sale/Contract apply unless otherwise stated in writing by ZOOK.

CAUTIONS

Rupture disks are precision instruments and must be handled with extreme care. Rupture disks should be installed only by qualified personnel familiar with rupture disks and proper piping practice.

Examine each disk carefully before installation. Handle with extreme care.

DO NOT USE IF THERE IS ANY INDICATION OF DAMAGE.

Refer to the appropriate ZOOK product bulletin for complete dimensions and product specifications/limitations.

Get the latest ZOOK installation guides and product literature on the worldwide web at www.zookdisk.com or follow this QR code on your smartphone to be connected directly to our website.



The disk tag is designed to provide critical information about the rupture disk and should NOT be used as a handle to hold, lift or adjust the assembly during installation. This practice can damage the disk resulting in failure of the disk.

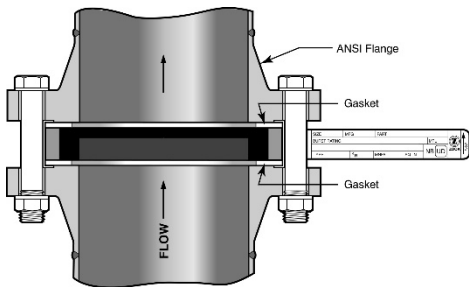

Figure 1
MONO / VAC Types

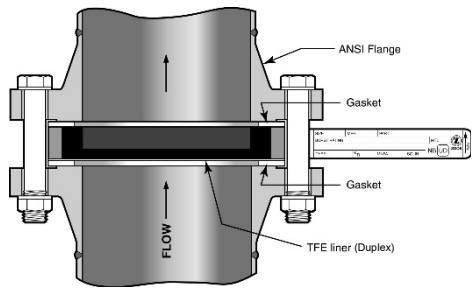

Figure 2
INVERTED, DUPLEX, FS-INV,
FSV-INV, UNI, UNI-LINED Types

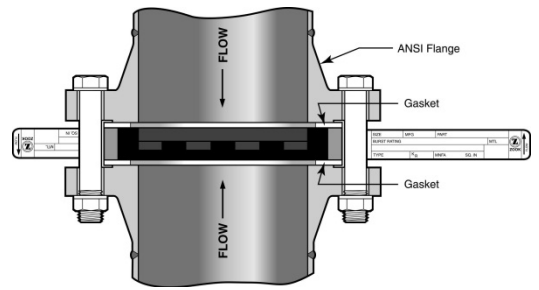

Figure 3
Two-Way Type

INSTALLATION (ALL RUPTURE DISK TYPES AND DEVICES)

To achieve accurate burst pressures and a leak-free joint, several steps are required. It is imperative that a proper bolt-up procedure is applied.

- 1) Inspect the Companion Flanges:
 - a. Before installing the assembly into the system, ensure that the companion flange gasket surfaces are clean and free from all rust, corrosion, and foreign material. The allowable imperfections in the flange gasket surface should not exceed the depth of the surface finish grooves, and that the radial marks are no deeper than the depth of the flange surface finish and less than 50% in length of the overall gasket sealing surface width.
 - b. To assure proper sealing of the assembly and flange gaskets parallelism, flatness, and waviness should be within 0.008" (0.2mm) or less.
- 2) Insert the disk assembly between the companion flanges insuring that ALL FLOW ARROWS ARE POINTING IN THE PROPER DIRECTION.

WARNING: If the rupture disk is installed upside down, the burst pressure may exceed the marked burst pressure. PAY CLOSE ATTENTION TO THE DIRECTIONAL ARROWS ON THE RUPTURE DISK ASSEMBLY

- 3) Install new gaskets between the rupture disk and the companion flanges. ZOOK recommends compressed fiber gasket no greater than 1/8" thick (sized to dimensions specified in Table 1 on page 4). The user is cautioned to select a gasket material that is suitable for the intended service and will resist "cold flow". In the event of cold flowing of the gaskets, the assembly torque will relax, which can result in erratic bursting of the rupture disk and/or leakage.
- 4) Do not apply any compounds to the gasket or seating surfaces.
- 5) Reinstall companion flange studs and nuts, making sure they are free of any foreign matter, and well lubricated. Lubricate the nut bearing surfaces as well. Lubrication is not required if PTFE coated fasteners are used.
- 6) Run-up all nuts finger tight while maintaining parallelism
- 7) Determine the recommended bolting torque from Table 2.
- 8) Using a calibrated torque wrench, apply torque incrementally in a minimum of three (3) passes [30%, 60%, 100% of specified recommended torque] using a crossing pattern tightening sequence (see diagrams below). After following this sequence, a final tightening should be performed using a circumferential pattern moving bolt-to-bolt to ensure that all bolts have been evenly torqued.
- 9) Verify parallelism is in accordance with 1) a. above.
- 10) Torqueing loss is inherent in any bolted joint. The combined effects of bolt relaxation, gasket creep, vibration in the system, thermal expansion and elastic interaction during bolt tightening contribute to torque loss. Companion flange torque values should be verified periodically at the system temperature.

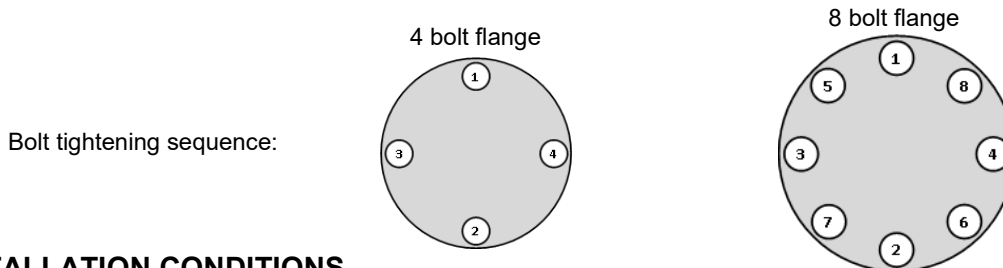

SPECIAL INSTALLATION CONDITIONS

NOTE: Use gasket dimensions shown in Table 1. Using incorrect gasket dimensions could affect the performance of the rupture disk.

1) Rupture disks with Spacer Rings – Figure 4

- a) Install the spacer ring on the downstream (vent) side of the rupture disk. The spacer ring thickness is determined based on using three (3) 1/8" thick gaskets in between the flanges, rupture disk, and the spacer ring.

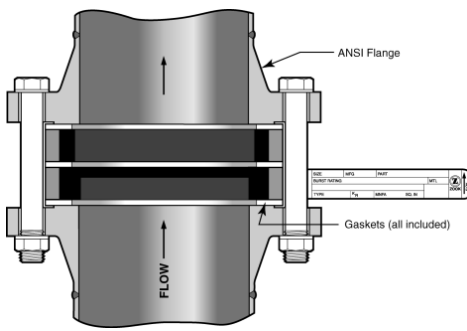

Figure 4
Disk w/Spacer Ring

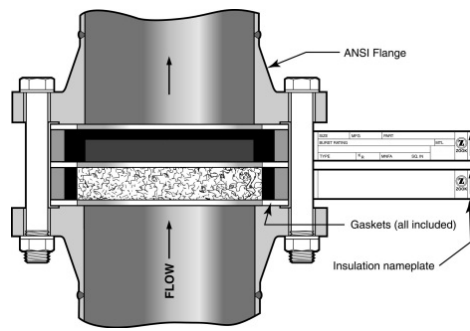

Figure 5
Disk w/Heat Shield

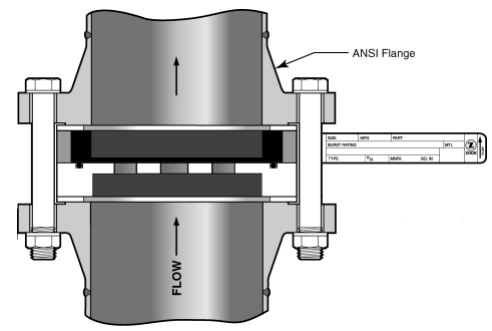

Figure 6
Disk w/Ext. Support

2) Rupture disks with heat shields – Figure 5

- a) Heat shield is supplied attached to disk and is provided with all required gaskets attached.
- b) Assembly is not designed to be used in liquid applications.

3) Rupture disks with External Vacuum Supports – Figure 6

- a) Install the external vacuum support on the upstream (process) side of the rupture disk using O-Ring supplied.

NOTE: No additional gasket is required between rupture disk and external support.

4) Rupture disks with Burst Indication (not shown)

WARNING:

FOR HAZARDOUS LOCATION INSTALLATION, AN INTRINSICALLY SAFE POWER TO THE RUPTURE DISK INDICATOR IS REQUIRED.

FOR SERVICES INVOLVING HIGHLY ELECTRICALLY CONDUCTIVE FLUIDS, USE A MONITORING DEVICE THAT WILL DETECT CHANGE IN RESISTANCE THROUGH THE ELECTRICAL CIRCUIT.

a) ZENSOR®

- i) The ZENSOR is an integral electrical device specifically designed for use with ZOOK Impervious Graphite Rupture Disks and is suitable for use in hazardous locations (Class I, II, and III, Division 1 and 2, Group A through G) provided it is used with an approved intrinsically safe electrical alarm monitor.
- ii) Rupture disk with Zensor is provided with all required gaskets attached.
- iii) THE RUPTURE DISK AND THE ZENSOR BRACKET MUST NOT BE IN DIRECT CONTACT WITH THE MOUNTING FLANGES OR THE FLANGE BOLTS. THIS CAN CAUSE INCIDENTAL GROUNDING OF THE DEVICE.

b) RDI and BA Indicating devices

- i) The RDI or BA assembly is installed on the vent side of the rupture disk assembly normally between the disk and the companion flanges.

NOTE: The RDI assembly is NOT a 'Flow Direction' sensitive device. However, it is recommended that the "shiny" side of the RDI is facing towards the rupture disk.

- ii) Place the indicator between the companion flange and disk making sure it is centered and concentric with each other.
- iii) No additional gasket is required on the vent side of the rupture disk assembly. Process side gasket is required.
- iv) It is recommended that the installation date is marked on the tag.

c) LEAK DETECTION (LD) OPTION

- i) The LD is installed immediately upstream (between the rupture disk and indicator) of the RDI or BA indicator.
- ii) Align outside diameter of LD with outside diameter of the indicator.
- iii) The LD may be held in place by using small piece of Scotch® tape over the outside diameter on both sides of the indicator. Locate tape 90° from both sides of identification tag. **Tape must not extend more than half way across gasket surface.**
- iv) After each leak or burst detection a replacement LD and RDI must be installed.

d) Wiring:

- i) Using approved Electrical Code Procedures, connect the lead wires to the burst detection circuit. Do not use the lead wire shield as a ground. The electrical operating limits of each device are indicated on the tag attached to the lead wire. If used in conjunction with ZOOK Model ZAM Plus Alarm Monitor, refer to the Installation Manual - Bulletin 350.

Max Voltage: 24 VDC

Max Current: 20 mA

Table 1 – Gasket Dimensions

NOMINAL SIZE		ID (IN)		OD (IN)														
NPS	DN	ANSI, ISO, PN20 & PN50	DIN, ISO, & JIS	ANSI			DIN & ISO					ISO ONLY		JIS				
				150	300	600	PN6	PN10	PN16	PN25	PN40	PN20	PN50	5K	10K	16K	20K	30K
½	15	0.88	0.93	1.75	2.00		1.73		2.01		1.75	2.00	1.89		2.17		2.40	
¾	20	1.13	1.13	2.13	2.50		2.13		2.40		2.13	2.50	2.09		2.36		2.60	
1	25	1.31	1.43	2.50	2.75		2.52		2.80		2.50	2.75	2.48		2.80		2.99	
1 ½	40	1.91	2.10	3.25	3.63		3.39		3.62		3.25	3.63	3.15		3.39		3.82	
2	50	2.50	2.65	4.00	4.25		3.78		4.21		4.00	4.25	3.54		3.98		4.37	
2 ½	65	3.25	3.25	4.75	5.00		4.59		5.00		4.75	5.00	4.52		4.76		5.39	
3	80	3.75	4.00	5.25	5.75		5.20		5.59		5.25	5.75	4.96	5.16	5.39		5.79	
4	100	5.00*	5.00*	6.75	7.00	*	5.98	6.38	6.61		6.75	7.00	5.75	6.14	6.38		6.69	
5	125	6.13	6.13	7.63	8.38	*	7.16	7.55	7.80		7.63	8.38	7.13	7.36	7.87		8.07	
6	150	7.13	7.13	8.63	9.75	*	8.15	8.58	8.82		8.63	9.75	8.31	8.54	9.25		9.76	
8	200	8.88*	9.00	10.88	12.00	*	10.31	10.75	11.18	11.42	10.88	12.00	10.12	10.51	11.2		11.54	
10	250	11.63	11.38	13.25	*	*	12.48	12.91	12.95	*	*	*	*	12.68	12.99	13.90	*	*
12	300	13.75	13.25	16.00	*	*	14.69	14.88	15.12	*	*	*	*	14.45	14.76	15.87	*	*
14	350	14.50	15.31	17.63	*	*	16.65	17.24	17.48	*	*	*	*	16.14	16.54	17.6	*	*
16	400	17.00	17.41	20.13	*	*	18.62	19.25	19.49	*	*	*	*	18.50	19.02	19.96	*	*
18	450	19.50	19.50	21.50	*	*	20.79	21.22	21.85	*	*	*	*	20.87	21.81	22.52	*	*
20	500	21.75	21.53	23.75	*	*	22.76	23.39	24.29	*	*	*	*	22.83	23.35	24.69	*	*
24	600	25.00	25.00*	28.13	*	*	26.73	27.36	28.9	*	*	*	*	27.09	27.44	28.78	*	*

*4"-300 ANSI and ISO PN50 ID equals 4.75"; 8"-300 ANSI and ISO PN50 ID equals 9.00"; 24" DIN PN16 and JIS 16K equals 25.80"

Table 2 – Torque Values

NOMINAL SIZE		TORQUE FT-LB (for N-m: multiply number below by 1.35)														
NPS	DN	ANSI			DIN & ISO					ISO ONLY		JIS				
		150	300	600	PN6	PN10	PN16	PN25	PN40	PN20	PN50	5K	10K	16K	20K	30K
½	15	5	7	13	6		10		17	5	10	8	14	5	8	
¾	20	7	13	23	10		17		27	7	17	9	16	7	12	
1	25	8	20	30	14		22		35	9	25	13	28	12	16	
1 ½	40	17	45	73	25	35	37	59	19	60	20	34	24	32		
2	50	29	22		26	41	45	63	34	25	19	42	21	21	35	
2 ½	65	37	30		20	32	40	86	44	25	18	27	27	27	41	
3	80	45	44		48	30	35	49	51	50	41	26	31	31	53	
4	100	28	59	*	46	32	53	73	32	71	18	32	40	41	71	
5	125	45	70	*	18	33	117	117	53	128	18	25	53	53	103	
6	150	50	59	*	32	53	104	129	65	67	46	53	55	59	102	
8	200	69	99	*	51	76	51	107	96	114	54	46	65	77	131	
10	250	54	*	*	37	55	68	*	*	*	52	68	98	*	*	
12	300	68	*	*	60	66	93	*	*	*	52	55	86	*	*	
14	350	99	*	*	66	64	88	*	*	*	42	53	122	*	*	
16	400	79	*	*	50	88	118	*	*	*	52	79	141	*	*	
18	450	101	*	*	60	75	113	*	*	*	74	73	176	*	*	
20	500	81	*	*	49	85	152	*	*	*	63	85	159	*	*	
24	600	143	*	*	93	136	219	*	*	*	107	135	193	*	*	

Actual field conditions may differ from room temperature conditions on which the above torque values are based on. In addition, these values are based on raised face welding neck flanges, free running treads and well lubricated bolts with a coefficient of friction of $\mu = 0.180$, 1/8" thk compressed fiber gaskets (sized to dimensions shown above) with design seating stress (γ) of 4400 psi and gasket factor (m) of 5.2. Re-torquing of bolts may be necessary to nullify loss caused by gasket compression set. ASME Code Sect. VIII Div. 1 was followed for estimating required seating and operating bolt loads.

Standard Conditions for Torque Calculations

- a) The torque values provided above should be used with caution. Engineering judgment and experience is needed to allow for proper interpretation. Due to the inherent variations in the coefficient of friction, both in the threads and between the nut face and clamped surface, there is no single "correct" tightening torque for all circumstances. A range of values can be determined however given the anticipated frictional scatter. The amount of frictional scatter, which the engineer allows for when determining the clamp force and tightening torque, should be based upon experimental results taken from the application.
- b) Recommended torque values do not consider piping stress or alignment.
- c) Consult ZOOK for recommended torque values for non-standard conditions.

www.zookdisk.com

Serving America, Central & South America
 16809 Park Circle Drive, Chagrin Falls,
 Ohio 44022 USA
 Toll Free: +1 800 543 1043
 Phone: +1 440 543 1010
 E-mail: sales@zookdisk.com

Serving Europe, Middle East & Africa
 Navigation House, Bridge Street
 Killamarsh, Sheffield,
 S21 1AL UK
 Phone: +44 (0) 1909 560999
 E-mail: sales.europe@zookdisk.com

Serving Canada
 4400 South Service Rd,
 Burlington, Ontario L7L 5R8 CA
 Toll Free: +1 800 370 6057
 Phone: +1 905 681 2885
 E-mail: sales.canada@zookdisk.com

Serving Asia Pacific
 Unit No.23A-05, Menara Landmark, No.12,
 Jalan Ngee Heng
 80000 Johor Bahru, Johor, Malaysia
 Phone: +60 (7) 2910099
 E-mail: sales.asia@zookdisk.com