



INSTALLATION INSTRUCTIONS

For UH & UHZ Series Forward Acting Rupture Disk Holders
Rupture Disk Series: FPB, FD, FTMT, SFA, SFAZ, FDZ, FPBZ

1) WARNING

- a) Read the complete instructions before attempting to install the rupture disk and holder assembly.
- b) It is the user's responsibility for the design of adequate venting and installation of adequate vent piping or directional flow after rupture occurs with the rupture disk as intended. When size is specified, ZOOK assumes that adequate provisions have been made by the purchaser and/or user for proper venting of a system to relieve the specific pressure. Locate the rupture disk where people or property will not be exposed to the system discharge in the event of rupture. Vent toxic or flammable fumes to a safe location to prevent personnel injury or property damage.
- c) It is the user's responsibility to specify the burst pressure rating at the coincident temperature at which the rupture disk is to be used. A rupture disk is a temperature sensitive device. The burst pressure of the rupture disk is directly affected by its exposure to the coincident temperature. Failure to utilize a rupture disk at the specified coincident temperature could cause premature failure or over pressurization of the system.
- d) Particles may discharge when the rupture disk ruptures. These particles may be part of the rupture disk itself, or other environmental matter in the system. It is the user's responsibility to ensure that the particles are directed to a safe area to prevent personnel injury or property damage.
- e) Rupture disk service life is affected by corrosion, creep and fatigue, and physical damage. These conditions will derate the rupture disk to a lower pressure. The user should be prepared to handle a premature failure of the rupture disk. The media or other environmental conditions should not allow for any build-up or solidification of media on the rupture disk. This may increase the burst rating of the rupture disk.
- f) ZOOK rupture disks, when installed in their respective holders correctly, will provide a very good seal for liquids and most gases or vapors. However, ZOOK cannot guarantee the leakage rate of the disk seal without prior knowledge of the requirement and details of the piping layout. Consult ZOOK for guidance if leakage is critical to the installation.
- g) The customer and/or its installer shall be responsible for the proper installation of rupture disk device into a system. **Recommended torque values do not consider piping stress or alignment.**
- h) Customer and/or its installers shall be responsible for improper installation and physical damage resulting therefrom, including, but not limited to, damage resulting from leakage, improper torquing, and/or failure to follow installation instructions. Incorrect torque may result in lower than expected burst pressure and/or leaks.
- i) ZOOK standard Terms and Conditions of Sale apply unless otherwise stated in writing by the manufacturer.

2) HOLDER INSPECTION AND PREPARATION – NEW HOLDERS

- a) Carefully remove the rupture disk holder from its packaging and disassemble by removing the pre-assembly tab screws for insert type holders, or pre-assembly capscrews for bolted type holders, and lift the outlet flange up and set aside. Discard the brown shipping paper sandwiched between the two halves of the holder.
- b) Wipe with a clean cloth and suitable solvent to remove all rust inhibitors and foreign material.
- c) Inspect the seat area for any scratches, dents, or nicks. Imperfections on these surfaces can cause leaks. **DO NOT USE** if any scratches, dents or nicks are detected, contact ZOOK immediately for instructions.
- d) The holder must not be machined or modified in any way without prior written approval from ZOOK.

www.zookdisk.com

Serving America, Central & South America
16809 Park Circle Drive, Chagrin Falls,
Ohio 44022 USA
Toll Free: +1 800 543 1043
Phone: +1 440 543 1010
E-mail: sales@zookdisk.com

Serving Europe, Middle East & Africa
Navigation House, Bridge Street
Killamarsh, Sheffield,
S21 1AL UK
Phone: +44 (0) 1909 560999
E-mail: sales.europe@zookdisk.com

Serving Canada
4400 South Service Rd,
Burlington, Ontario L7L 5R8 CA
Toll Free: +1 800 370 6057
Phone: +1 905 681 2885
E-mail: sales.canada@zookdisk.com

Serving Asia Pacific
Menara LGB TTDL, Unit 6-3A, Level 6,
1, Jalan Wan Kadir, Taman Tun Dr. Ismail,
60000 Kuala Lumpur, Malaysia
Phone: +603 2706 0098
E-mail: sales.asia@zookdisk.com



INSTALLATION INSTRUCTIONS

For UH & UHZ Series Forward Acting Rupture Disk Holders
Rupture Disk Series: FPB, FD, FTMT, SFA, SFAZ, FDZ, FPBZ

3) HOLDER INSPECTION AND PREPARATION – EXISTING HOLDERS

- a) For existing installations remove the complete assembly (rupture disk and holder) from the piping by removing the companion flange studs and nuts and place on a clean flat surface.
- b) Disassemble the assembly by removing the pre-assembly tab screws for insert type holders and lift the outlet flange up and set aside.
- c) Remove the used rupture disk from the holder.
- d) Inspect the sealing bite indentation formed on the disk inlet seat formed during proper makeup and torquing of the holder. The indentation should be consistent around the circumference of the rupture disk and be visible to the naked eye. **DO NOT USE** the holder if any inconsistencies are observed, contact ZOOK immediately for instructions. Inconsistencies generally indicate a worn holder which can lead to leakage and/or erratic burst pressures.
- e) Inspect the holder's mating surfaces for foreign material. Remove any adhered gasket material from the previous installation and clean the gasket surfaces of the holder thoroughly. Dirt and grit on these surfaces can cause leaks.
- f) Inspect the seat area for any scratches, dents, or nicks. Imperfections on these surfaces can cause leaks. **DO NOT SCRAPE OR SCRATCH** any seating surface. If wiping these surfaces with a clean cloth and suitable solvent does not remove surface residue, fine emery cloth or steel wool may be utilized. Care should be exercised not to exert sufficient pressure on the emery cloth or steel wool to cut or groove these sealing surfaces. **DO NOT USE** if any scratches, dents or nicks cannot be removed, contact ZOOK immediately for instructions.
- g) The holder must not be machined or modified in any way without prior written approval from ZOOK.

4) ASSEMBLY OF THE RUPTURE DISK AND HOLDER

- a) **CAUTION:** All ZOOK Rupture Disks are recommended for installation into holders manufactured by ZOOK ONLY.
- b) **CAUTION:** Rupture disks are precision instruments and must be handled with extreme care. Rupture disks should be installed only by qualified personnel familiar with rupture disks and proper piping practice.
- c) **CAUTION:** ZOOK does not recommend reinstalling a rupture disk that has been removed from its holder. Reinstallation may adversely affect the sealing capabilities and/or the performance of the rupturedisk.
- d) Place the holder inlet on a clean flat work surface with the flow arrows pointing up from the work surface.
- e) Carefully remove the disk from its package.
- f) Examine the disk carefully before installation. **DO NOT USE IF THERE IS ANY INDICATION OF DAMAGE.** Handle with extreme care.
- g) Place the disk into the inlet counterbore with the flow arrows pointing up from the work surface so the convex (dome) side of the disk faces upwards. **DO NOT USE A GASKET BETWEEN THE DISK AND HOLDER.**
- h) Carefully align and place the outlet flange into the inlet counterbore with the flow arrows pointing up from the work surface.
- i) For "insert" type holders, fasten the assembly together by reinstalling the pre-assembly tabs and screws. The pre-assembly screws should be snug, **NOT** wrench-tight.

www.zookdisk.com

Serving America, Central & South America
16809 Park Circle Drive, Chagrin Falls,
Ohio 44022 USA
Toll Free: +1 800 543 1043
Phone: +1 440 543 1010
E-mail: sales@zookdisk.com

Serving Europe, Middle East & Africa
Navigation House, Bridge Street
Killamarsh, Sheffield,
S21 1AL UK
Phone: +44 (0) 1909 560999
E-mail: sales.europe@zookdisk.com

Serving Canada
4400 South Service Rd,
Burlington, Ontario L7L 5R8 CA
Toll Free: +1 800 370 6057
Phone: +1 905 681 2885
E-mail: sales.canada@zookdisk.com

Serving Asia Pacific
Menara LGB TTDL, Unit 6-3A, Level 6,
1, Jalan Wan Kadir, Taman Tun Dr. Ismail,
60000 Kuala Lumpur, Malaysia
Phone: +603 2706 0098
E-mail: sales.asia@zookdisk.com

j) For UHZ holders with Teflon Sleeve Insert and Sintered:

1) New Installation

- (1) Inspect the O-ring groove of the holder for any scratches, dents, nicks, or debris. Imperfections in the groove can cause leaks. DO NOT USE if any scratches, dents, or nicks are present, contact ZOOK immediately for instructions.
- (2) Inspect the provided O-ring for scratches, dents, or nicks. DO NOT USE if O-ring is damaged, contact ZOOK immediately for instructions.
- (3) Place the O-ring in the groove of the holder and follow section 4) i).
- (4) O-ring is a custom size, contact ZOOK for replacements.
- (5) Figure 1 displays a teflon sleeved holder. Teflon sintered holders are similar except they do not have a sleeve.

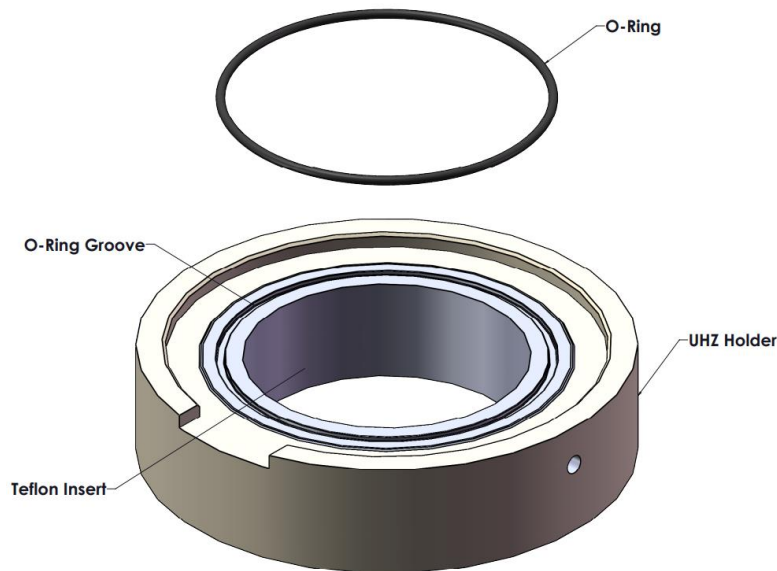

Figure 1. UHZ Holder with Teflon Sleeved Insert

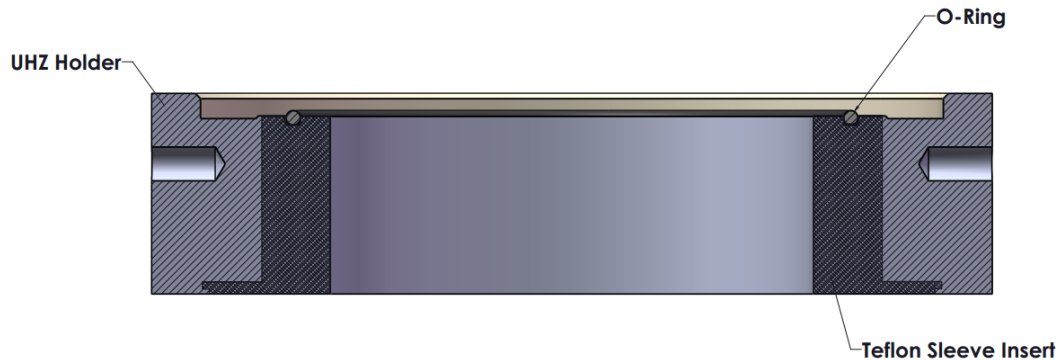

Figure 2. UHZ Holder with Teflon Sleeved Insert Cross Section



INSTALLATION INSTRUCTIONS

For UH & UHZ Series Forward Acting Rupture Disk Holders
Rupture Disk Series: FPB, FD, FTMT, SFA, SFAZ, FDZ, FPBZ

5) INSTALLATION OF THE ASSEMBLY (RUPTURE DISK AND HOLDER) INTO THE SYSTEM

- a) To achieve a high degree of success in attaining accurate burst pressures and a leak-free joint, several steps are required. It is imperative that a regimented bolt-up procedure is applied.

Inspect the Companion Flanges:

- (1) Before installing the assembly into the system, ensure that the companion flange gasket surfaces are clean and free from all rust, corrosion, and foreign material. The allowable imperfections in the flange gasket surface should not exceed the depth of the surface finish grooves, and that the radial marks are no deeper than the depth of the flange surface finish and less than 50% in length of the overall gasket sealing surface width.
 - (2) To assure proper sealing of the assembly and flange gaskets parallelism, flatness, and waviness should be within 0.008" (0.2mm) or better.
- b) Insert the assembly between the companion flanges insuring that ALL FLOW ARROWS POINTING IN THE PROPER DIRECTION. The concave side of the rupture disk should be facing towards the process pressure.
- c) Install new gaskets between the assembly and the companion flanges. We recommend compressed fiber gasket no greater than 1/16" (1.6mm) thick. The user is cautioned to select a gasket material that is suitable for the intended service and will resist "cold flow". In the event of cold flowing of the gaskets, the assembly torque will relax in non-pre-torqueable holders, which can result in erratic bursting of the rupture disk and/or leakage.
- d) Do not apply any compounds to the gasket or seating surfaces.
- e) Reinstall companion flange studs and nuts, making sure they are free of any foreign matter, and well lubricated. Lubricate the nut bearing surfaces as well. Lubrication is not required if PTFE coated fasteners are used.
- f) **WARNING:** The disk tag is designed to provide critical information about the Rupture Disk only and should NOT be used as a hand hold to lift or adjust the assembly during installation. This practice can damage the disk resulting in failure of the disk below its marked burst pressure.
- g) Run-up all nuts finger tight while maintaining parallelism in accordance with 5.a.2.
- h) Using a torque wrench, develop the required torque incrementally in a minimum of four (4) steps in a crisscross pattern. The initial torque should be no more than 30% of the final required torque listed in table #1. After following this sequence, a final tightening should be performed bolt-to-bolt to ensure that all bolts have been evenly torqued. Under torquing can cause lower than expected burst pressures.
- (1) The use of hardened washers will enhance the installation by reducing the friction due to possible galling of the nut bearing surfaces.
- i) Verify parallelism is in accordance with 5.a.2.
- j) Companion flange torque values should be verified periodically at the system temperature.

www.zookdisk.com

Serving America, Central & South America
16809 Park Circle Drive, Chagrin Falls,
Ohio 44022 USA
Toll Free: +1 800 543 1043
Phone: +1 440 543 1010
E-mail: sales@zookdisk.com

Serving Europe, Middle East & Africa
Navigation House, Bridge Street
Killamarsh, Sheffield,
S21 1AL UK
Phone: +44 (0) 1909 560999
E-mail: sales.europe@zookdisk.com

Serving Canada
4400 South Service Rd,
Burlington, Ontario L7L 5R8 CA
Toll Free: +1 800 370 6057
Phone: +1 905 681 2885
E-mail: sales.canada@zookdisk.com

Serving Asia Pacific
Menara LGB TTDL, Unit 6-3A, Level 6,
1, Jalan Wan Kadir, Taman Tun Dr. Ismail,
60000 Kuala Lumpur, Malaysia
Phone: +603 2706 0098
E-mail: sales.asia@zookdisk.com

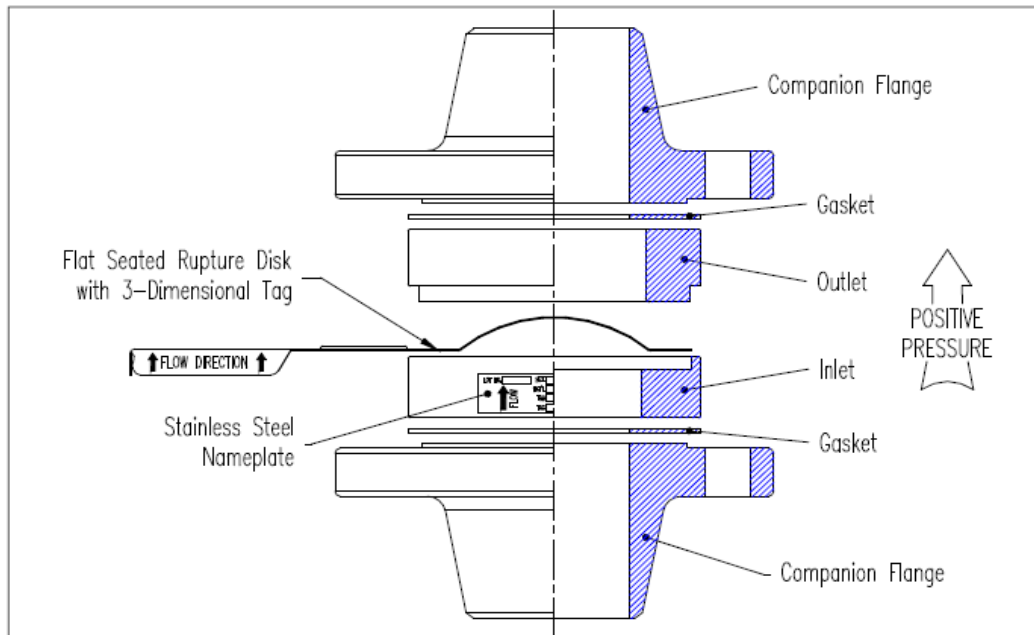

Figure 3. UH Series Holder Installation Diagram

TABLE 1 - RECOMMENDED FLANGE BOLT TORQUE VALUES

IMPERIAL 193 Grade B7 Studs and A194 Grade 2H Nuts				METRIC ISO 898 -1 Class 8.8			
Nominal Diameter of Bolt (inches)	Number of Threads (per Inch)	Recommended Torque Ft-Lbs		Thread Designation	Thread Pitch (mm)	Recommended Torque Nm	
		Recommended 30,000 Psi Bolt Stress	Maximum 45,000 Psi Bolt Stress			Recommended 205 N / mm ² Bolt Stress	Maximum 310 N / mm ² Bolt Stress
1/2	13	30	51	M10	1.5	20	30
5/8	11	59	88	M12	1.75	34	52
3/4	10	105	158	M14	2	55	83
7/8	9	170	255	M16	2	86	130
1	8	255	383	M18	2.5	118	178
1 1/8	8	378	566	M20	2.5	167	254
1 1/4	8	533	798	M22	2.5	228	346
1 3/8	8	725	1,087	M24	3	286	434
1 1/2	8	961	1,440	M27	3	423	641
1 5/8	8	1,244	1,865	M30	3.5	577	875
1 3/4	8	1,571	2,355	M33	3.5	788	1,190
1 7/8	8	1,968	2,893	M36	4	1,010	1,530
2	8	2,401	3,599	M39	4	1,305	1,977
2 1/4	8	3,471	5,203	M42	4.5	1,622	2,458
2 1/2	8	4,819	7,223	M45	4.5	2,013	3,051

www.zookdisk.com

Serving America, Central & South America
 16809 Park Circle Drive, Chagrin Falls,
 Ohio 44022 USA
 Toll Free: +1 800 543 1043
 Phone: +1 440 543 1010
 E-mail: sales@zookdisk.com

Serving Europe, Middle East & Africa
 Navigation House, Bridge Street
 Killamarsh, Sheffield,
 S21 1AL UK
 Phone: +44 (0) 1909 560999
 E-mail: sales.europe@zookdisk.com

Serving Canada
 4400 South Service Rd,
 Burlington, Ontario L7L 5R8 CA
 Toll Free: +1 800 370 6057
 Phone: +1 905 681 2885
 E-mail: sales.canada@zookdisk.com

Serving Asia Pacific
 Menara LGB TTDI, Unit 6-3A, Level 6,
 1, Jalan Wan Kadir, Taman Tun Dr. Ismail,
 60000 Kuala Lumpur, Malaysia
 Phone: +603 2706 0098
 E-mail: sales.asia@zookdisk.com