

1) WARNING

- a) Read the complete instructions before attempting to install bonding wire to bonding tag.
- b) The customer and/or its installer shall be responsible for the proper bonding of the rupture disk assembly. DO not touch rupture disk dome with multimeter probe.
- c) Customer and/or its installers shall be responsible for improper installation and physical damage resulting from, including, but not limited to, damage resulting from leakage, improper torquing, improper electrical hookup, and/or failure to follow installation instructions.
- d) ZOOK standard Terms and Conditions of Sale apply unless otherwise stated in writing by the manufacturer.
- e) User is responsible for deciding whether bonding point is acceptable for their application.
- f) The disk dome is a sensitive component and in order to avoid damage under no circumstances should the disk dome be used as a part of any continuity check during testing/installation.
- g) **CAUTION: Liners, gaskets, other insulating components and scored rupture disks will impede bonding ability until rupture disk has burst. Scored rupture disks assemblies with oxide layer are properly bonded after burst.**

2) INSTALLATION BONDING WIRE TO ZOOK BONDING TAG

- a) As soon as the rupture disk with bonding tag is unpacked, inspect it thoroughly for any damage that may have occurred in transit. Save all packing material until the inspection is completed. If damage is found or bonding tag is missing, notify ZOOK immediately for guidance and do not use disk.
- b) User is responsible to check continuity of rupture disk assembly as per 2.) e.) 2.) and 2.) e.) 3.).
- c) Install the rupture disk assembly in accordance with the specific installation instructions.
- d) User is responsible to install and check continuity between user-installed ground wire and ZOOK bonding tag.
- e) Specifications:
 - 1) All ZOOK rupture disk assemblies with bonding tag have been inspected and verified in accordance with NFPA 77 2014 standard (maximum resistance limit: 10 Ω , Chapter 10.1.1).
 - 2) ZOOK Factory tested for maximum resistance limit: 5 Ω
 - 3) Rupture disk assemblies have been tested for continuity from bonding hole to metal portion of rupture disk.

5mm hole Bonding sample

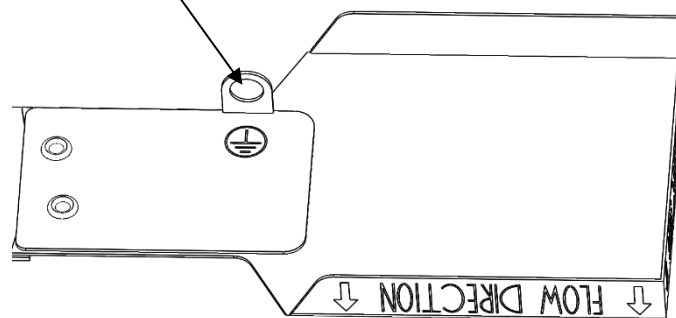

www.zookdisk.com

Serving America, Central & South America
16809 Park Circle Drive, Chagrin Falls,
Ohio 44022 USA
Toll Free: +1 800 543 1043
Phone: +1 440 543 1010
E-mail: sales@zookdisk.com

Serving Europe, Middle East & Africa
Navigation House, Bridge Street
Killamarsh, Sheffield,
S21 1AL UK
Phone: +44 (0) 1909 560999
E-mail: sales.europe@zookdisk.com

Serving Canada
4400 South Service Rd,
Burlington, Ontario L7L 5R8 CA
Toll Free: +1 800 370 6057
Phone: +1 905 681 2885
E-mail: sales.canada@zookdisk.com

Serving Asia Pacific
Menara LGB TTDI, Unit 6-3A, Level 6,
1, Jalan Wan Kadir, Taman Tun Dr. Ismail,
60000 Kuala Lumpur, Malaysia
Phone: +603 2706 0098
E-mail: sales.asia@zookdisk.com